

## Virtual Backup InFile Delta Details

With Virtual Backup InFile Delta technology, it is now possible to backup very large files daily. There are two different modes of operation available (“Differential” and “Incremental”) for InFile Delta backup. Both modes will use approximately the same amount of disk space storage on the server.

- “Differential Delta” will facilitate ease of restore. The delta is generated by comparing with the latest uploaded “Full” file so the delta file can grow daily and uses more bandwidth during backup. For restoration, the full file and a single delta file is required to restore the file to a specific point-in-time.
- “Incremental Delta” will facilitate ease of backup. The delta is generated by comparing with the latest uploaded “Full” or “Delta” file so the delta file is the smallest possible and uses the least bandwidth during backup. For restoration, the full file and all delta files up to the required point-in-time is required to restore the file to a specific point-in-time.

The major differences are summarized in the following table:

InFile Delta Technology	Pros	Cons
<p><b><u>Differential</u></b></p> <p>Always use the latest uploaded “Full” file to generate the delta file.</p>	<p>For restore, just need the full and a delta to recover to a specific point-in-time.</p>	<p>The daily delta file will be larger than incremental delta and needs more bandwidth to upload.</p>
<p><b><u>Incremental</u></b></p> <p>Always use the latest uploaded file (whether “Full” or “Delta”) to generate the delta file.</p>	<p>Daily delta files only shows the difference between the current file and previous upload file. The daily delta file will be smaller than the differential delta and so faster to upload.</p>	<p>For restore, need to use the full and all deltas up to the point-in-time to recover to a specific point-in-time. If any delta file is corrupted, the file can only be recovered up to the point-in-time before the corrupted delta.</p>

## Delta Generation

The delta is generated by extracting the differences between the latest file to backup and the original file stored on the server. Both files are divided into individual blocks using the same block size and the blocks compared to determine whether they're the same or different. The differences are extracted into the delta file.

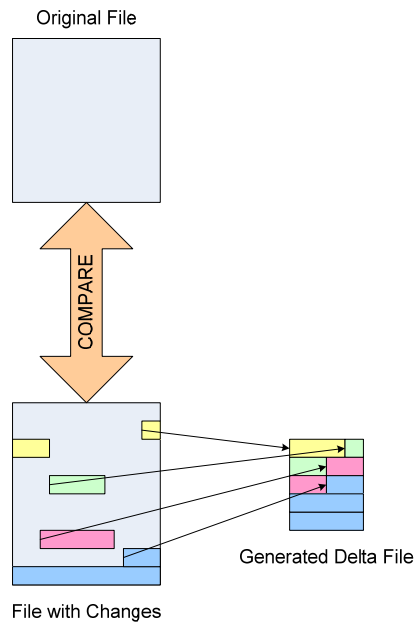

## Block Size Setting

Using a different block size setting can affect the speed of generation and size of the generated delta. Generally speaking, the relationship between the block size setting and delta generated is as follows:

- The smaller the block size, the delta file generated will be smaller but takes longer to process
- The larger the block size, the delta file generated will be larger but is faster to process.

The block size setting available are Auto, 1K, 2K, 4K, 8K, 16K, 32K, 64K, 128K, 256K, 512K and 1M. With "Auto", the block size used will be initially set using the backup file size according to the table below.

Initial Full File Size	Auto Block Size Used
> 15G	64K
> 8G ≤ 15G	32K
> 2G ≤ 8G	16K
> 500M ≤ 2G	8K
≤ 500M	4K

## During Backup

Assume the initial full file is 100MB and grows daily by 10MB. The files uploaded to the server and the approximate storage space required is as follows:

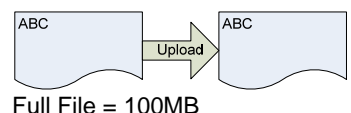
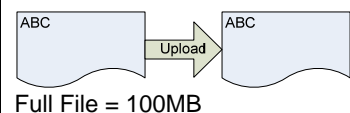
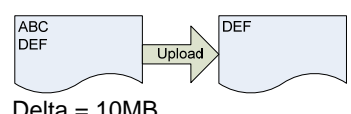
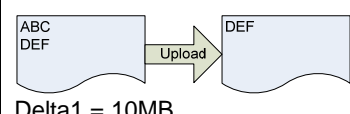
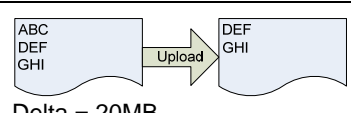
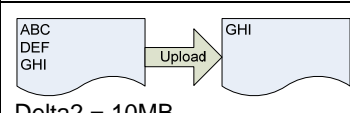
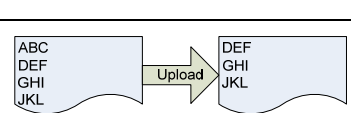
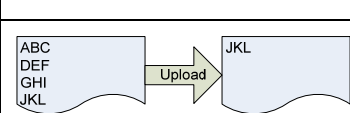
#	File Size	Daily Upload to OBS		Storage Space Required (MB)*	
		Differential	Incremental	Differential	Incremental
1	100 MB	 <p>Full File = 100MB</p>	 <p>Full File = 100MB</p>	$\frac{\text{(Full) } 100}{\text{Total} = 100}$	$\frac{\text{(Full) } 100}{\text{Total} = 100}$
2	110 MB	 <p>Delta = 10MB</p>	 <p>Delta1 = 10MB</p>	$\frac{\text{(Full) } 100}{\text{+ (Delta) } 10}$ $\text{Total} = 110$	$\frac{\text{(Full) } 100}{\text{+ (Delta1) } 10}$ $\text{Total} = 110$
3	120 MB	 <p>Delta = 20MB</p>	 <p>Delta2 = 10MB</p>	$\frac{\text{(Full) } 100}{\text{+ (Delta) } 20}$ $\text{Total} = 120$	$\frac{\text{(Full) } 100}{\text{+ (Delta1) } 10}$ $\text{+ (Delta2) } 10$ $\text{Total} = 120$
4	130 MB	 <p>Delta = 30MB</p>	 <p>Delta3 = 10MB</p>	$\frac{\text{(Full) } 100}{\text{+ (Delta) } 30}$ $\text{Total} = 130$	$\frac{\text{(Full) } 100}{\text{+ (Delta1) } 10}$ $\text{+ (Delta2) } 10$ $\text{+ (Delta3) } 10$ $\text{Total} = 130$

\* Storage space is approximate

## During Restore

Assume restoring the various files backed up above.

#	Files Downloaded from OBS to Restore	
	Differential	Incremental
1		
2		
3		
4		